

PEERLESS

1976-77

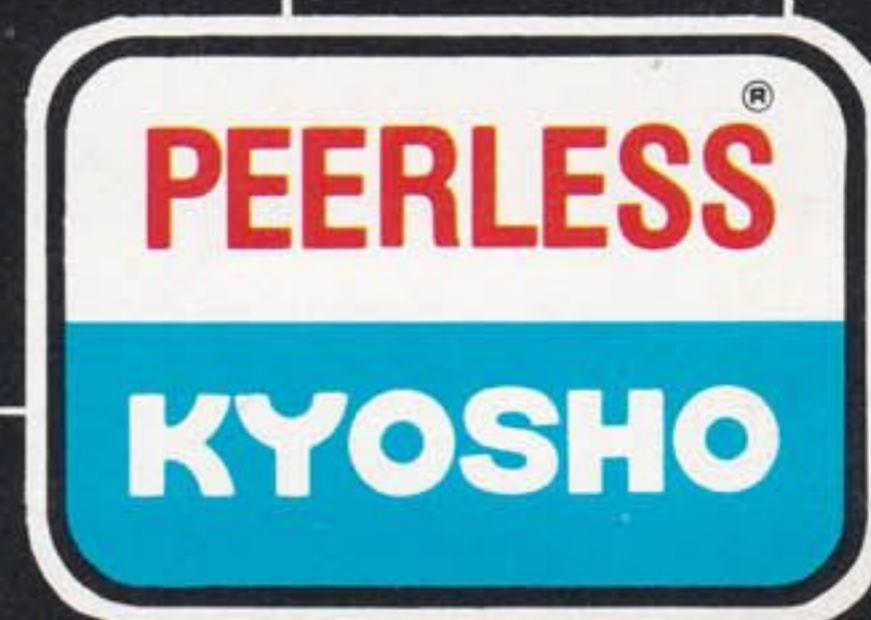

KYOSHO

Flymate
SERIES

The Slingsby
KESTREL 15

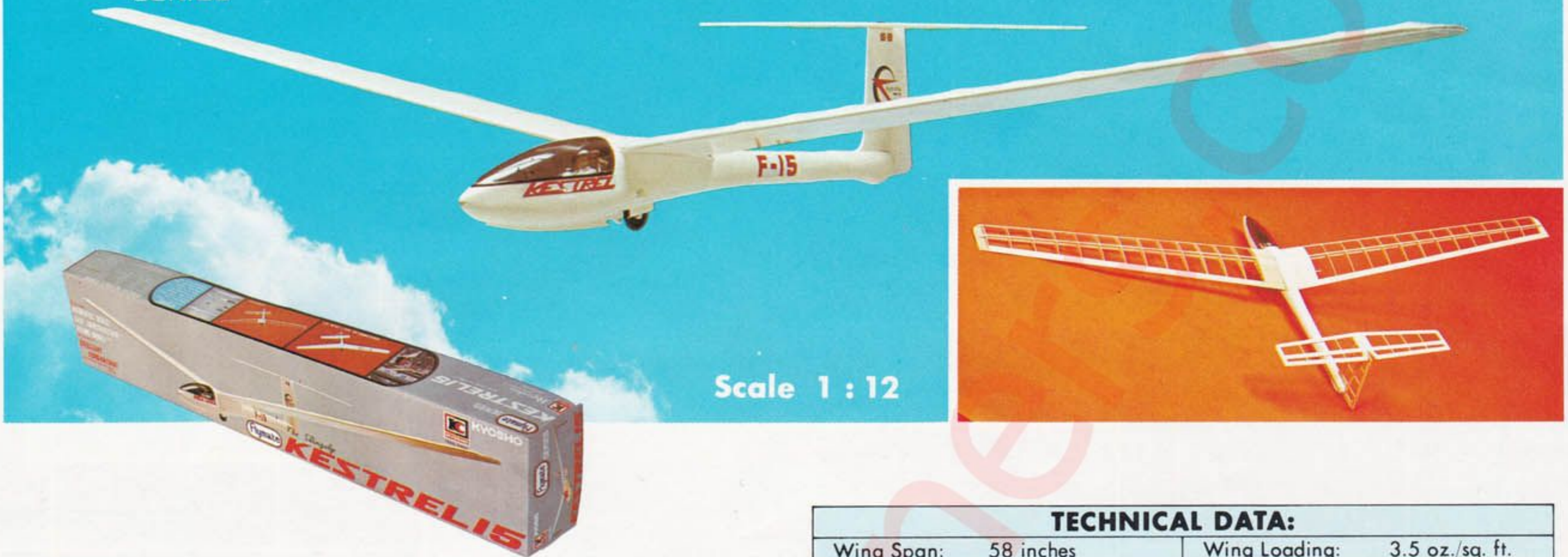

Scale 1 : 12

TECHNICAL DATA:

Wing Span:	58 inches	Wing Loading:	3.5 oz./sq. ft.
Length:	26 inches	Aspect Ratio:	15
Wing Area:	248 sq. inches	Scale:	1 : 12
Weight:	0.37 lbs.		

NO. 2001 KESTREL 15 FREE-FLIGHT SAILPLANE

This has to be one of the finest sailplane kits ever designed and manufactured. Authentic 1 : 12 scale. An excellent combination of ABS vacuum formed plastic fuselage and balsa wing, makes the kit outstanding. Precisely molded parts are included in the kit for difficult to assemble portions, such as the cockpit, canopy, frame, etc.. Precision die-cut balsa parts are furnished for the wing and tail, so that it can be assembled by beginners into an accurate and beautiful model.

The righthand photo shows the structure of the kit. The kit includes easy-to-complete semi-finished fuselage. Wing is designed for easy assembly without warping.

For easy on assembly, a vacuum formed and injected molded fuselage is furnished with this kit. This insures the completion of the beautiful Free-Flight KESTREL 15.

The wing is designed to be detached for ease of transportation. The KESTREL 15 can easily be converted to a motor glider using an .02 miniature gas engine.



Scale 1 : 5.6

NO. 2003 LIBELLE 2700 R/C SAILPLANE KIT

Another superior design from Kyosho. Highly efficient for either slope or thermal soaring, the LIBELLE 2700 can also be powered by an .09 engine. Construction has been greatly simplified. The front half of the fuselage and parts of the main wing are made from injection molded ABS plastic. The rear half of the fuselage is vacuum-formed ABS and pre-welded into one piece. It has a wing span of 105¹/₃ inches, and a fuselage length of 46¹/₂ inches. Weight (less R/C) is 2.8 pounds. The wing and stabilizer use a new plastic covering, and both are detachable with strong, durable steel joints. All necessary parts included except R/C equipment and engine. Designed for 2-3 channel R/C.

KYOSHO

ABS[®] KIT
SERIES

Beautiful
CIRRUS 3000



Scale 1 : 6

A GIANT 10 FEET PLUS

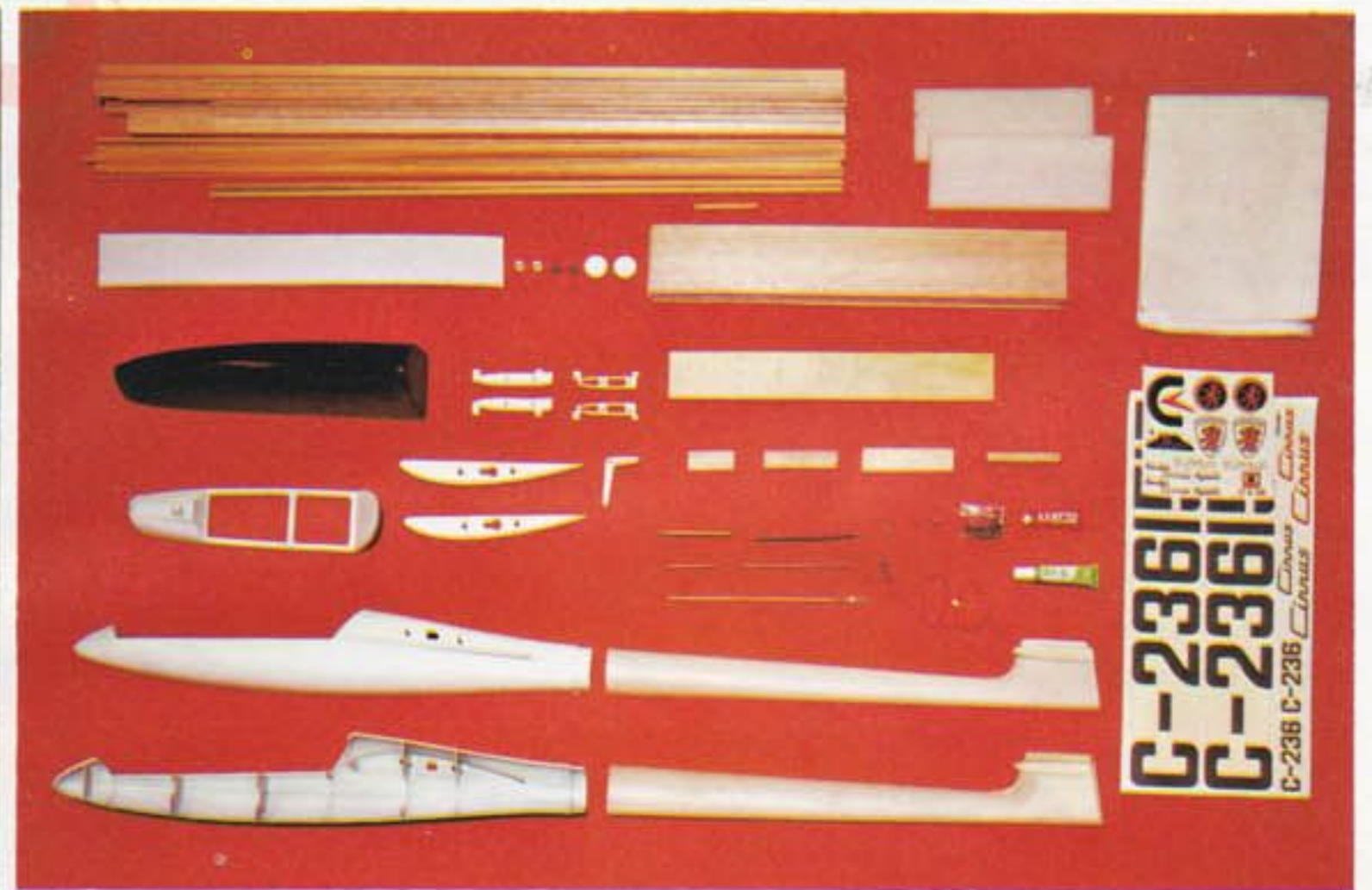

NO.2002 CIRRUS3000 R/C SAILPLANE

A magnificent R/C sailplane that is the ultimate in slope and thermal soaring. Especially designed by Kyosho flight engineers for both the beginner and skilled builder. It is basically designed for 2-Channel operation, but easily converted for use with up to 6-Channel equipment. Construction has been simplified as never before and in a short time you will be enjoying the thrill of slope or thermal gliding with the skill of an expert. We believe this to be the finest sailplane kit ever produced and we know you will confirm this statement after you have assembled it. It is a fascinating non-flying model for interior decoration, too.

The front half of the fuselage and major wind rib parts are made of injection molded **ABS** plastic. The rear half of the fuselage, which requires additional strength, is made of vacuum-formed **ABS** very light and durable plastic. The kit includes all necessary prefabricated metal parts. Precision die-cut and shaped prime balsa wood is used throughout. Wings and stabilizer are detachable for ease in transportation. The

canopy easily locks on or off for adjustment of R/C mechanisms. Finally, we have included a step-by-step illustrated instruction book with easy-to-follow flight guide for beginners.

TECHNICAL DATA

Wing Span:	118 3/4"	Weight (2ch R/C):	3 lbs
Wing Area:	806 sq. in	Weight (less R/C):	2.2 lbs
Fuselage Length:	46 3/4"	Wing Loading (2ch R/C):	8 1/2 oz/ sq. ft
Stabilizer Area:	130 sq. in		

KIT CONTENTS:

Semi-finished Fuselage (ABS resin)	Sheets of Silk Span
Rod Adjusters (3 pieces)	Full Size Plans(2 sheets)
Wing Panel Installation Parts	Dowels (2 pieces)
Colored Decals (2 sheets)	Giant Opaque Canopy
Numbered Die-cut Balsa Wing Parts	Lead Weight (3.5 oz)
Specially Made Horns (2 pieces)	Step-by-Step Manual
Finished Cockpit (ABS resin)	R/C Equipment Not Included

NO.2101 NEWPORT R/C SAILING YACHT

A beautiful model sailing yacht kit, complete with the finest Nylon sails, super-detailed scale metal fittings and all necessary parts to make the finest model on the market today. Everything, except the R/C equipment.

This kit reproduces in miniature, the classic beauty of today's sailing yacht with every detail and provides the builder with hours of pleasure. The kit has been so simplified that almost anyone can produce a superb sailing model. Materials are selected from the finest available and are a genuine pleasure to work with. The easy-to-follow plans and instructions reduces difficult operations to a minimum. The kit includes fittings not available elsewhere. The ABS vacuum formed plastic hull requires very little trimming.

TECHNICAL DATA:

Length:	32 inches	Total Sail Area:	342 sq. inches
Beam:	8.7 inches	Keel Weight:	39 oz.
Mast:	47 inches	Boat Weight:	60 oz.
Main Sail Area:	233 sq. inches	Total Weight with R/C Unit:	95 oz.
Fore Sail Area:	109 sq. inches		

KIT CONTENTS:

Pre-finished ABS vacuum formed plastic hull, Nylon cloth sails, printed plywood deck, precision metal fittings, full colored decals, mast and special fittings, cabin, hatch, Nylon cord, brass plated deadeyes, battery case and full size step-by-step plans and instructions.



NO.2102 CAPRI R/C CABIN POWER CRUISER

An authentic model cabin cruiser kit, complete with two Mabuchi electric motors, drive unit, scale metal fittings and all necessary parts to complete the model, except the R/C equipment.

It is designed for simplified R/C operation...allowing for forward, backward and stand-still operation. Twin electric motors with twin screws give the model unusual acceleration. This kit captures the authenticity of modern cabin cruiser construction and provides hours of pleasure during assembly. The kit has been designed so that even a beginner can produce a craftsman-like job. Only the finest of materials have been selected and this speeds assembly. Included are easy-to-follow plans and instructions, which are complete and easy to understand. The kit includes metal parts not normally found in a kit of this type. The pre-finished ABS vacuum formed hull requires a minimum of trimming.

KIT CONTENTS:

Pre-finished ABS vacuum formed plastic hull, ABS plastic deck, ABS plastic cabin, windshield, two heavy-duty electric motors, precision metal fittings, sharp printed full color decals, battery case and full size step-by-step plans and instructions. Everything in fact, except the R/C equipment.

TECHNICAL DATA:

Length:	33 inches	Boat Weight:	35 oz.
Height:	10.5 inches	Total Weight with R/C Unit:	70 oz.
Beam:	9.3 inches	Mabuchi 6V DC RC360 Motors:	TWO
Draught:	1.5 inches	Uses(4)"A"PenCells(NOT INCLUDED)	

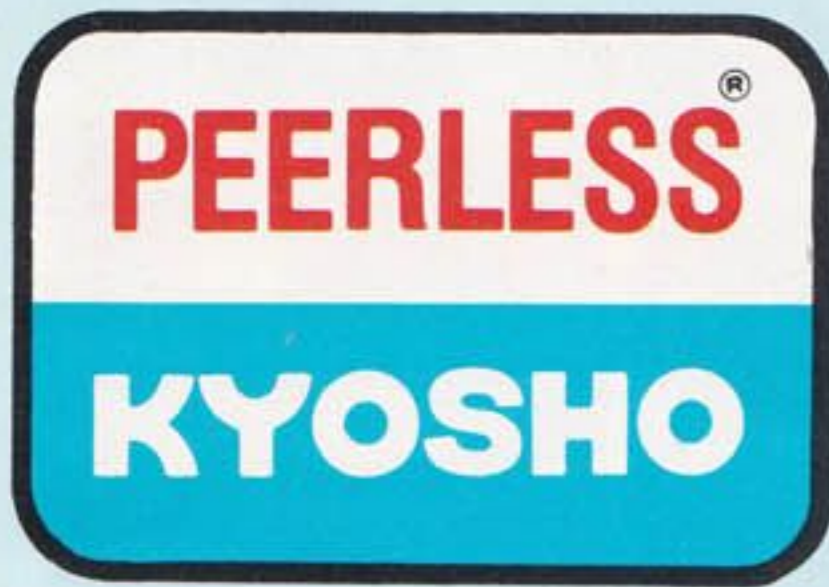

MARINE DRIVE ACCESSORIES

BY

PEERLESS/KYOSHO

HERE AT LAST . . .

A line of top quality electric marine drive accessories at unbelievable low prices . . . and the star feature is a special 12 volt D.C. Mabuchi motor of *fantastic power* engineered and manufactured by the largest motor manufacturer in the world . . .

And, you can buy them separately or as a set . . . motor with single screw drive and motor with twin screw drive. Also available are the marine drive parts individually packaged.

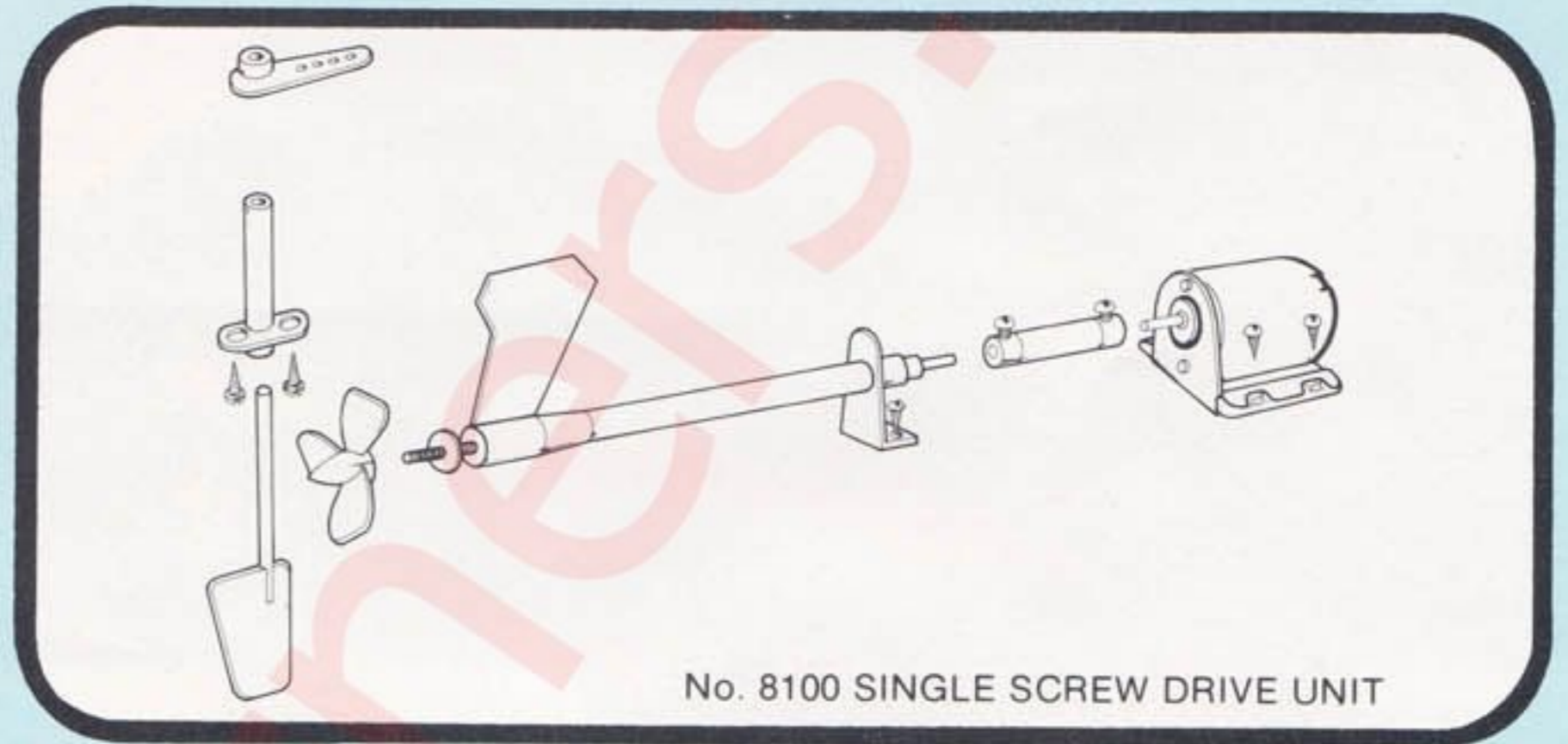

No. 8100 SINGLE SCREW DRIVE UNIT

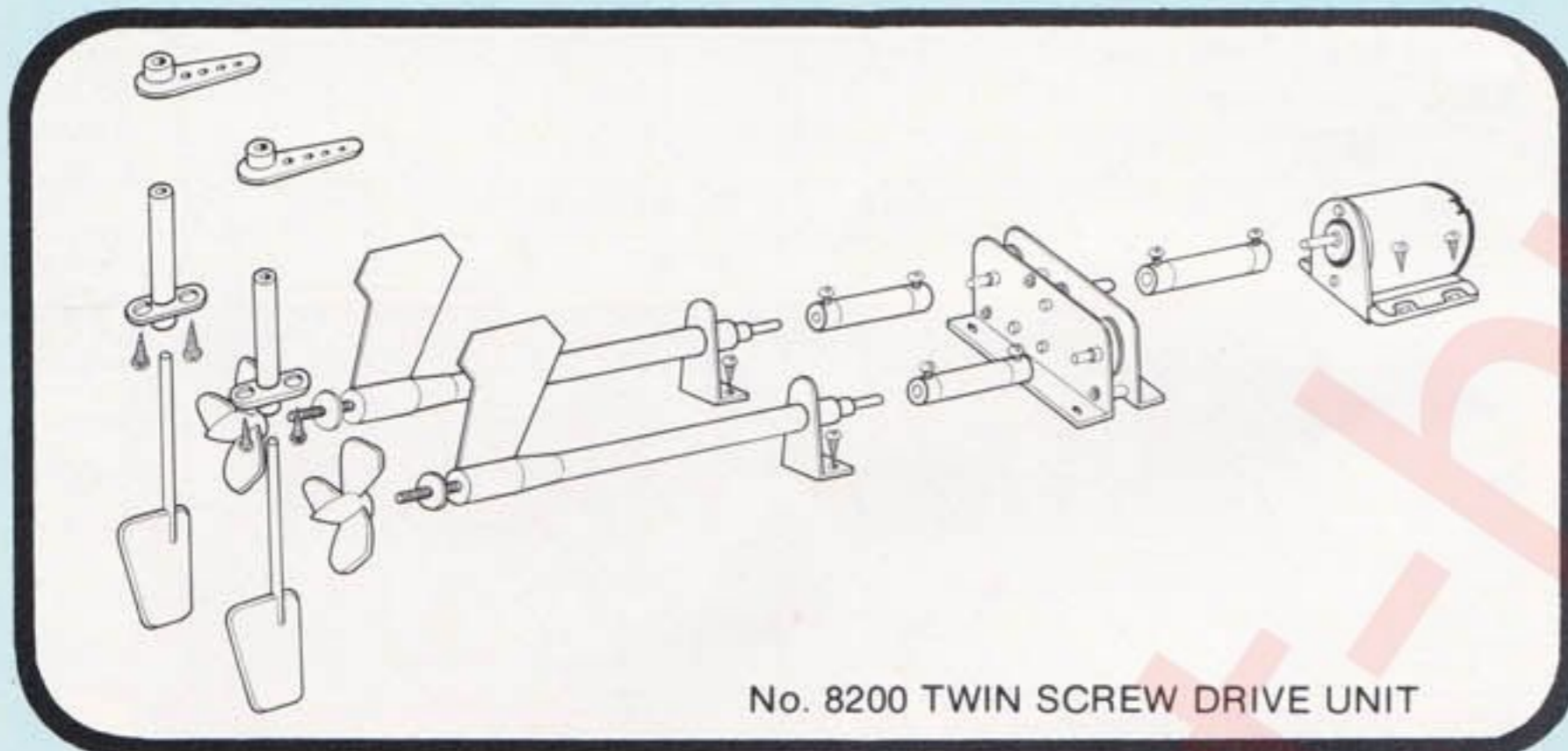

No. 8200 TWIN SCREW DRIVE UNIT

Only the finest materials are used in the manufacture of these units. For example, the motor mount is zinc plated steel, the flexible coupling is durable heavy rubber with metal ends. The Propeller Shaft, Stuffing Box, Stuffing Box Bracket and Rudder Assembly are all Chrome Plated steel! The Propeller and Propeller Bracket are CHROME PLATED BRASS!



TECHNICAL DATA PEERLESS/KYOSHO RS-54 MOTOR

VOLTAGE	Operating Range	6.0 - 12.0 V. DC
	Nominal	12.0 V. Constant
NO LOAD	Speed	14800 rpm
	Current	0.48 amp
AT MAXIMUM EFFICIENCY	Speed	12500 rpm
	Current	2.65 amp
	Torque	2.03 oz-in

MARINE ACCESSORIES

CAT. NO	DESCRIPTION	RETAIL
8000	12V DC MOTOR WITH BRACKET	\$ 9.95
8100	SINGLE SCREW DRIVE UNIT KIT WITH MOTOR	19.95
8200	TWIN SCREW DRIVE UNIT KIT WITH MOTOR	32.95

MARINE DRIVE PARTS

CAT. NO	DESCRIPTION	RETAIL
8001	GEAR BOX ASSEMBLY	\$3.00
8002	FLEXIBLE COUPLING WITH SCREWS	1.25
8003	PROPELLER SHAFT 2.6 mm DIA. x 10"	.50
8004	STUFFING BOX	.85
8005	NYLON SPACER WASHER	.15
8006	PROPELLER, BRASS 1-1/2" DIA.	3.40
8007	PROPELLER BRACKET, BRASS	4.00
8008	STUFFING BOX BRACKET	.30
8009	RUDDER ASSEMBLY	4.65

DASH 7 POP BUGGY

Scale 1 : 8



NO.2103 DASH 7 POP-BUGGY R/C CAR

This smartly designed dune buggy is for .15 or .20 gas engines and 2-Channel radio control equipment. It features an easy-to-start built-in pull-cord starter; a big heat sink duraluminum chassis; special steel suspension system; body made of ABS plastic; and fast and easy changing of gears with a 6-way ratio.

It has been designed and track tested for easy R/C remote operation, on the roughest of surfaces... with tight cornering and a minimum of slippage at high speed. It is a superior racing car from every angle.

TECHNICAL DATA:

Wheel Base:	11. 8"	Gear Ratio	70 : 10
Front Wheel Tread	8. 0"		70 : 14
Rear Wheel Tread	8. 6"		72 : 12
Body Length	19. 1"		72 : 16
Body Width	11. 0"	Centrifugal Clutch	
Body Height	6. 1"	Weight	5.1 lbs

KIT CONTENTS:

Accessoires	Die Cast Wheels
Oversized Tires	Pull Starter
Large Aluminium Heat Sink	Suspension Joints
Double-Face Bond Tape	Dust Cover
Bumper	Decal
Fuel Tank	ABS Vacuum-Formed Plastic Body

NOTE: Engine and Radio Control unit are not included.



NO. 2104 DASH 8 RACING CYCLE R/C KIT

Construction is so simplified that even beginners can build this kit. The beautiful streamlined body which is made of pre-colored ABS plastic resembles the B.M.W. Side Car of West Germany. Designed for 2 channel R/C and .15 to .20 engine. Kit includes 2 Scale Drivers, die cast aluminum chassis, centrifugal clutch, belt type brake (nylon), heat sink, fuel tank, tires and all parts except R/C and Engine. Cycle is 15.4 inches long, 5.3 inches high and has a wheel base of 6.5 inches. Overall width with side car is approximately 11 inches. Total weight less R/C and engine is 5.5 pounds. Illustrated manual with easy to follow instructions.



NO. 2105 DASH 9 AMPHIBIOUS BUGGY R/C KIT

Something new and different in the model world. The R/C Buggy that operates in water as well as on land. This unique model features a built-in engine starter and a duct-fan type propeller for safety and power. The plastic body is made in two sections and is water-tight and rust proof when assembled. Wheels are made of plastic and O-rings are used to seal the body completely. The overall length is 19.7 inches with an 11.4 inch wheel base. Overall width is 9.5 inches. Designed for Proportional 3 channel 2 servo R/C and any .15 to .20 engine. Kit includes two large mufflers, die cast heat sink and tooled clutch bell assembly. R/C unit and engine not included.

ANOTHER KYOSHO ENGINEERING MARVEL!

PEANUT BUGGY R/C KIT

WITH "EXCLUSIVE" REVERSING MECHANISM

Scale 1 : 10

KIT FEATURES

REVERSING MECHANISM . . . durable, simplified belt drive mechanism that is easy to operate.

INDEPENDENT SUSPENSION . . . 4 wheel flexible suspensions that operate on any type surface.

ENGINE COOLING SYSTEM . . . cooling fan mounted directly over engine cools automatically.

BUILT-IN STARTER . . . pull type starter for starting engine with a minimum of effort.

SUPERIOR KIT . . . features include pneumatic tires, spoke type metal wheels, die cast gear case and muffler . . . and all necessary parts except engine and R/C equipment.



NO. 2106 PEANUT DUNE BUGGY

The latest engineering marvel from PEERLESS/KYOSHO . . . the .09 Peanut Buggy R/C Kit. Available in two body styles . . . Dune Buggy or Sport Coupe Wagon. Designed for .09 engine and 2 channel 2 servo Radio Control.



ENGINE AND R/C UNIT NOT INCLUDED

TECHNICAL DATA

Body Length	12½"	Gear Ratio	20:1
Body Width	6½"	Engine	.09
Body Height	4"	Radio	2 ch 2 servo
Wheel Base	8"	Patents Pending	

Scale 1 : 10



NO. 2107 PEANUT WAGON BUGGY

F/F TURBO COMMANDER 690

TWIN RUBBER-POWERED WITH SYNCHROMESH GEAR MECHANISM (PAT. PENDING)

REALISTICALLY SMOOTH & LONGER FLIGHT

EASY CONSTRUCTION DIE CUT Balsa FUSELAGE • STYROFOAM PLASTIC WINGS

WITH RUBBER WINDER

TECHNICAL DATA	
Length	16 inches
Wing Span	24 inches
Wing Area	76.7 sq. inches
Total Weight	0.13 lbs.
Wing Loading	12 gr dm ²
Scale	1:25

KIT CONTENTS

FUSELAGE: DIE CUT Balsa SHEETS, MOLDED PLASTIC PARTS, TRANSPARENT WINDSHIELD
WING & TAIL: STYROFOAM AIRFOIL SECTION WING AND STABILIZER, Balsa RUDDER
MECHANISM: SYNCHRO GEARS & FLEXIBLE WIRE SHAFT
POWER: WORLD FAMOUS JAPANESE MADE RUBBER BANDS
AND . . . TWO PROPELLERS, SPINNERS, COWLINGS, WHEELS AND DECALS



NO. 1001 F/F TURBO COMMANDER 690

KIT FEATURES

First in the world . . . Twin Rubber-Powered Scale Model Plane . . . Simplified Mechanism . . . Synchronesh Gears & Flexible Wire Shafts . . . Synchronized Twin Propellers which provide for longer flight than in routine single rubber-

powered models . . . World famous Japanese made Rubber Bands . . . Die-Cut Balsa Fuselage and Styrofoam Airfoil Wing and Tail . . . Molded Plastic Parts . . . Shock absorbing Rubber Nose.

PEERLESS CORPORATION 3919 "M" STREET, PHILADELPHIA, PA. 19124 U.S.A.

©1976 PEERLESS CORPORATION PRINTED IN U.S.A.

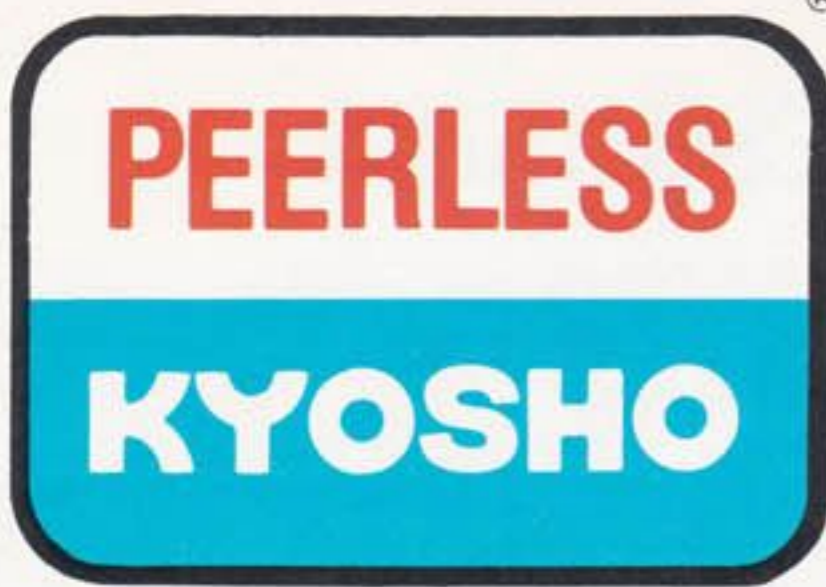

NEW... from Peerless/ KYOSHO

Two New Super Kits Designed For Radio Control

NO. 2108 SPEARFISH R/C CABIN CRUISER

The Spearfish has been awarded the distinction of being one of the favorite pleasure boats of England's Royal Family.

An authentically scaled model, the kit is complete with two Mabuchi 6V DC electric motors, drive unit, scale metal fittings and all necessary parts to build this beautiful model. R/C equipment and batteries are not included in the kit.

The pre-finished ABS vacuum formed plastic hull, deck and cabin require a minimum of trimming and simplifies construction, so that even a beginner can produce a craftsman like job. Full size step-by-step plans and instructions are included along with metal parts not normally found in a kit of this type. The Spearfish is designed for simplified R/C control . . . allowing for forward and reverse operation with the addition of a speed control such as the Peerless No. 8301. The Peerless Speed Control is not included in the kit, but it is readily available from your dealer.



SPEARFISH

Scale 1:6

KIT CONTENTS:

Pre-finished ABS vacuum formed plastic hull, deck and cabin. Two heavy duty 6V DC motors, micro switch, battery box, drive unit and over 60 precision detailed metal fittings.

TECHNICAL DATA

Length: 32 inches	R/C System: 2 channel
Height: 9 inches	Mabuchi 6V DC Motors: 2
Beam: 9 inches	Batteries Not Included

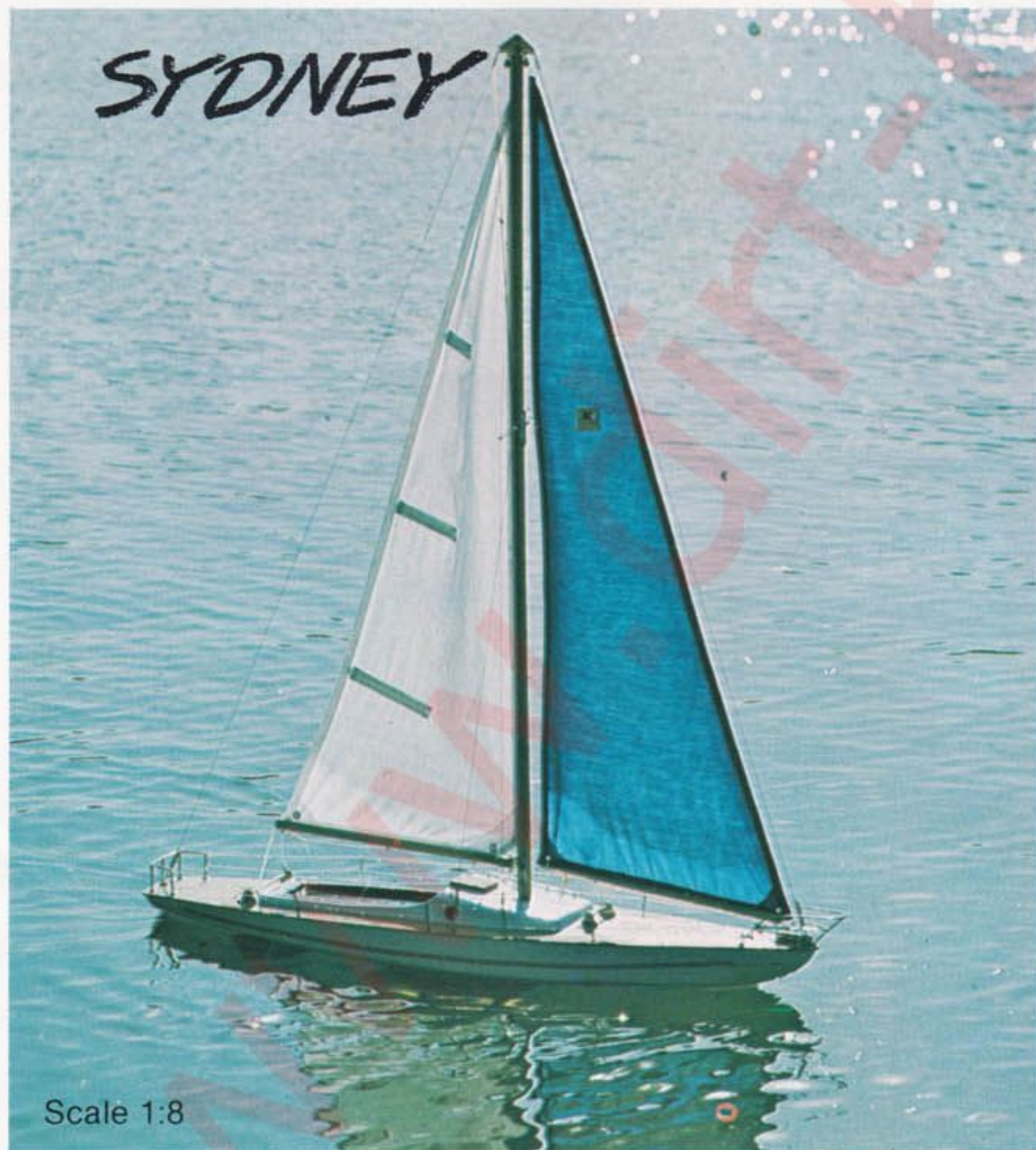

SYDNEY

Scale 1:8

NO. 2109 SYDNEY R/C SAILING YACHT

Meet Sydney . . . a beautifully designed and detailed model sailing yacht kit. Everything necessary to build this model is included in the kit. Pre-finished ABS vacuum formed plastic hull, cabin and hatch with a minimum of trimming. Precision die cut plywood parts including a printed deck. Factory finished sailcloth sails, mast, pre-formed and drilled keel weight, 70 precision metal fittings . . . everything, except the R/C equipment.

Easy to follow step-by-step full size plans and instructions that reduce difficult operations to a minimum, and greatly simplifies assembly. Materials are selected from the finest available and are easy to work with. Even a beginner will find that construction is not beyond his capabilities.

KIT CONTENTS:

Pre-finished ABS vacuum formed plastic hull, cabin and hatch. Mast and special fittings, finished sails, printed plywood deck, precision metal fittings, keel weight, full size plans, stainless rigging and many other extras.

TECHNICAL DATA

Length: 32 inches	Total Sail Area: 406 sq. inches
Beam: 9 inches	Boat Weight: 63 oz.
Height: 48 inches	R/C System: Single Channel
Mast: 34 inches	R/C Equipment: Not Included

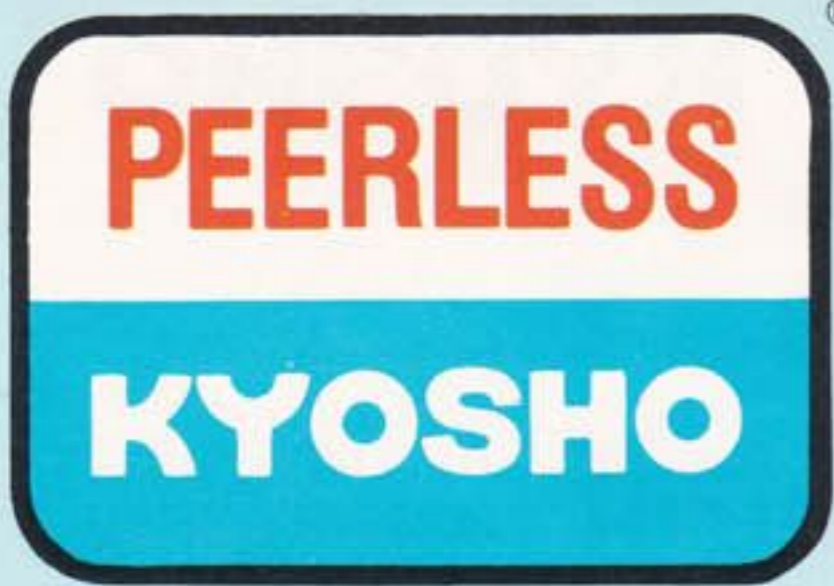

NEW PEERLESS/KYOSHO ACCESSORIES FOR ELECTRIC MARINE DRIVES



SPEED CONTROL

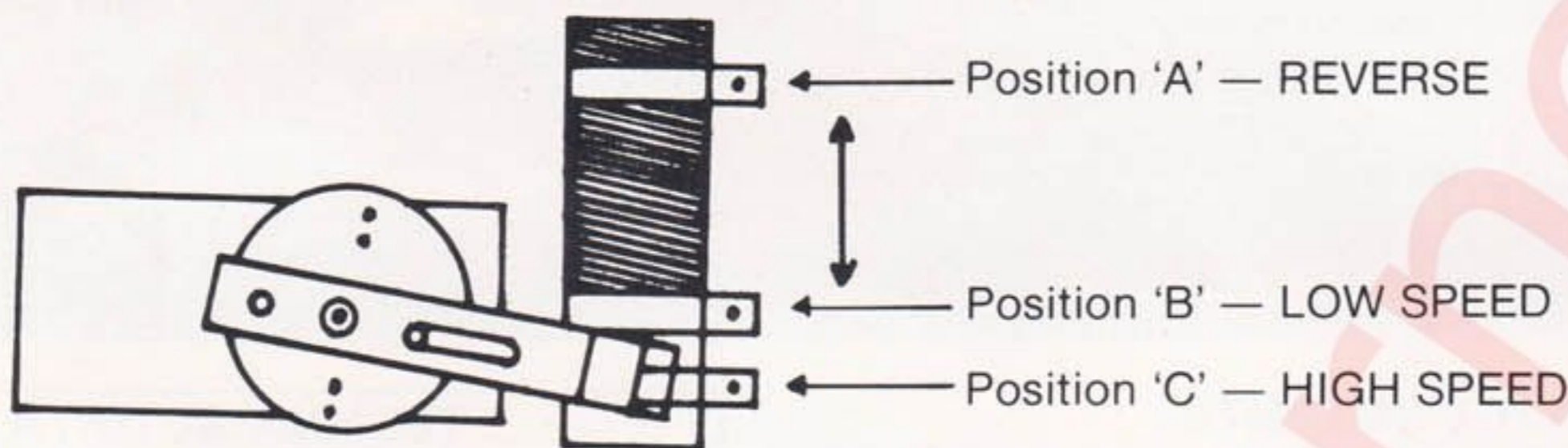

NO. 8301 SPEED CONTROL

The Peerless/Kyosho Speed Control was designed for use with the Capri and Spearfish electric motor Cruisers. However, it works equally well with the Peerless/Kyosho Marine Drive Motor and similar 12 Volt DC motors on the market.

The Speed Control can be used when installing proportional radio control units in R/C boats. In addition to controlling the speed, it also provides for forward and reverse operation. The unit can be connected to any standard proportional servo. Complete instructions are included.

NO. 8302 'NOISE KILLER'

The 'Noise Killer' is a noise suppressor to be used with electric motors for R/C models when applicable. In many instances the electric motor will cause interference with the receiver. The 'Noise Killer' eliminates this problem, and can be used with any 6-12 volt DC motor.

The unit consists of two chokes and two condensers pre-soldered to a terminal with leads. Complete instruction sheet included. Installation is simple and quick.

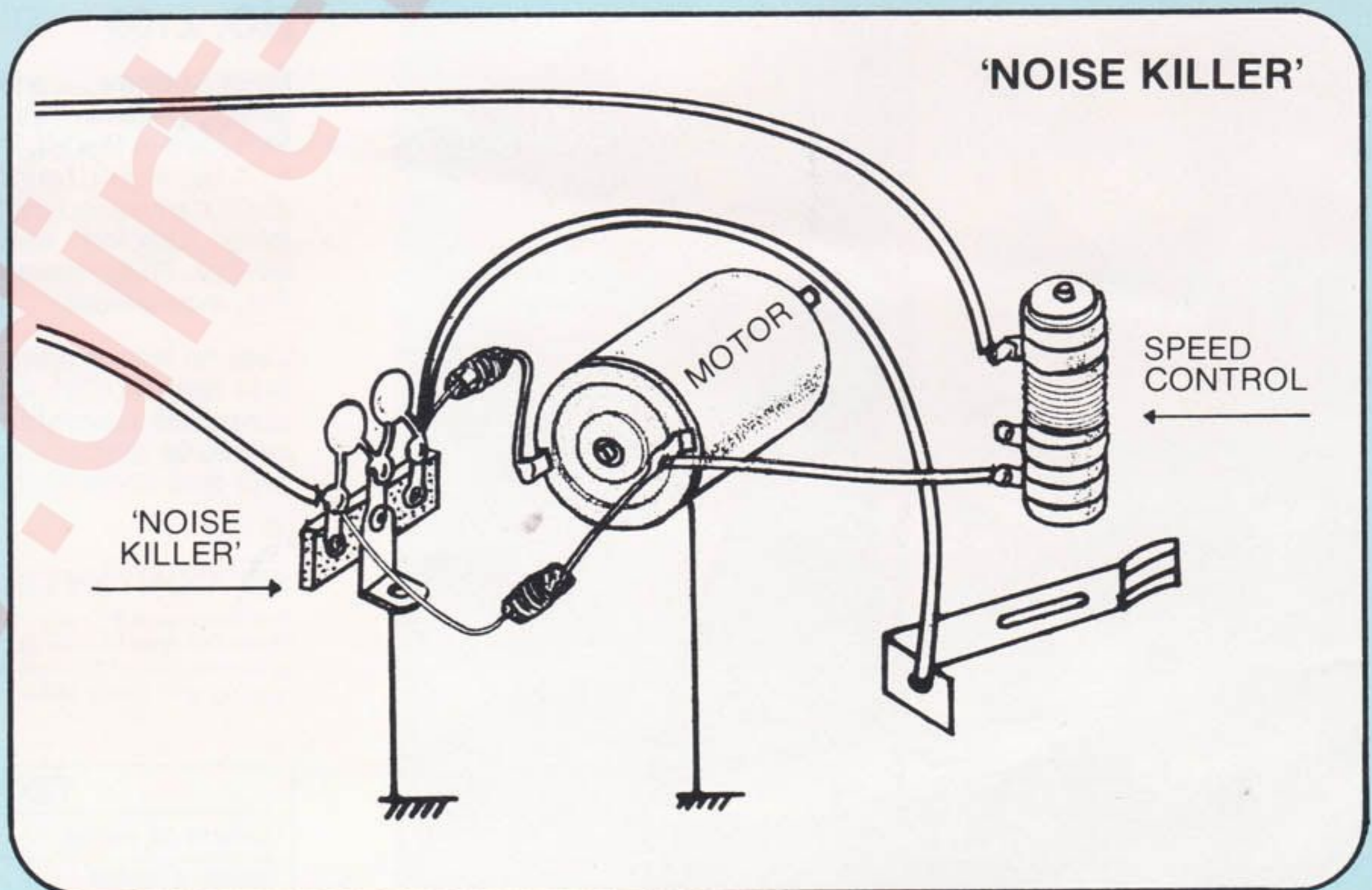

Typical Hook-up Of Accessories To Motor

DATE ORDERED	DATE RECEIVED
YOUR ORDER NO.	DEPT.
ORDERED BY	
CREDIT APPROVED	

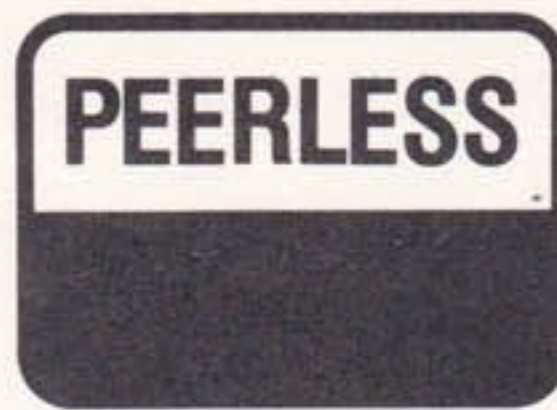

PEERLESS CORPORATION

3919 "M" STREET
PHILADELPHIA, PA. 19124

PHONE: (215) 831-0900 CABLE: PEERCOR PHILA.

INVOICE NO.	DATE
SALESMAN	DATE SHIPPED
SHIPPED VIA	
TERMS	

ORDER FORM

INVOICE TO: _____

SHIP TO: _____

PEERLESS 1:35 SCALE MILITARY KITS					
QUANT.	ITEM	DESCRIPTION	PACK	WT.	RETAIL
Ea.	3501	45 TON TANK TRANSPORTER	6	15	18.00
Ea.	3502	155mm HOWITZER	12	11	7.00
Ea.	3503	DODGE WEAPONS CARRIER	12	11	7.50
Ea.	3504	M6 37mm GUN CARRIAGE **	12	10	7.50
Ea.	3505	DODGE COMMAND CAR	12	10	7.50
Ea.	3506	DODGE PERSONNEL CARRIER	12	13	9.00
Ea.	3507	ARMORED SCOUT CAR **	12	11	9.00
Ea.	3508	BRITISH MILITARY TRUCK **	12	12	9.00
Ea.	3509	BRITISH QL GUN PORTEE	12	13	9.00
Ea.	3510	BRITISH FIELD GUN TRACTOR **	12	14	7.50
Ea.	3511	DODGE FIELD AMBULANCE	12	11	7.50
Ea.	3512	GERMAN RSO/1 TRACTOR	12	11	8.00
Ea.	3513	GERMAN RSO/3 TRACTOR *	12	9	8.00
Ea.	3514	GMC 6x6 CARGO TRUCK *	12	12	9.00
Ea.	3515	GMC 6x6 DUMP TRUCK *	12	12	9.00
Ea.	3516	M8 75mm HOWITZER CARRIAGE *	12	9	7.00
Ea.	3517	"STUART VI" LIGHT TANK *	12	9	7.00
Ea.	0351	ASSORTMENT (3 Each) 3503, 3504, 3510	1	11	90.00
Ea.	0352	ASSORTMENT (3 Each) 3506, 3507, 3508, 3509	1	12	108.00

PEERLESS/KYOSHO "SUPER" KITS					
QUANT.	ITEM	DESCRIPTION	PACK	WT.	RETAIL
Ea.	1001	TURBO COMMANDER 690	24	22	9.95
Ea.	2001	KESTREL 15 GLIDER	6	10	12.75
Ea.	2002	CIRRUS 3000 SAILPLANE **	3	20	84.95
Ea.	2003	LIBELLE 2700 SAILPLANE **	3	16	84.95
Ea.	2101	NEWPORT SAILING YACHT **	3	25	64.95
Ea.	2102	CAPRI CABIN CRUISER **	3	16	54.95
Ea.	2103	DASH 7 POP BUGGY **	2	15	99.95
Ea.	2104	DASH 8 RACING CYCLE	2	14	74.95
Ea.	2105	DASH 9 AMPHIBIOUS BUGGY	2	20	134.95
Ea.	2106	.09 PEANUT BUGGY **	2	7	74.95
Ea.	2107	.09 PEANUT WAGON BUGGY **	2	7	74.95
Ea.	2108	SPEARFISH CABIN CRUISER *	3	18	64.95
Ea.	2109	SIDNEY SAILING YACHT *	3	38	79.95

PEERLESS/KYOSHO MARINE ACCESSORIES					
QUANT.	ITEM	DESCRIPTION	PACK	WT.	RETAIL
Ea.	8000	12V DC MARINE MOTOR	12	5	9.95
Ea.	8100	SINGLE SCREW DRIVE UNIT	12	10	19.95
Ea.	8200	TWIN SCREW DRIVE UNIT	6	7	32.95
Ea.	8301	SPEED CONTROL *	12	1	7.00
Ea.	8302	'NOISE KILLER' *	12	1	5.00

PEERLESS/KYOSHO MARINE DRIVE PARTS					
QUANT.	ITEM	DESCRIPTION	PACK	WT.	RETAIL
Ea.	8001	GEAR BOX	12	1	3.00
Ea.	8002	FLEXIBLE COUPLING	12	1	1.25
Ea.	8003	PROPELLER SHAFT	12	1	.50
Ea.	8004	STUFFING BOX	12	1	.85
Ea.	8005	NYLON WASHER	12	1	.15
Ea.	8006	PROPELLER, L.H.	12	1	3.40
Ea.	8007	PROPELLER BRACKET	12	1	4.00
Ea.	8008	STUFFING BOX BRACKET	12	1	.30
Ea.	8009	RUDDER ASSEMBLY	12	1	4.65
Ea.	8010	PROPELLER, R.H. *	12	1	3.40

* DENOTES NEW 1977 RELEASE
 ** DENOTES PRICE CHANGE

PRICES SUBJECT TO CHANGE WITHOUT NOTICE

FREIGHT POLICY

\$1000 Net or Over: Full Freight Allowed

All Claims Must be Postmarked Within 5 Days of Receipt of Goods.
 Our Responsibility Ceases Upon Delivery to Carrier in Good Order.
 No Returns Accepted Without Written Prior Authorization.
 All Authorized Returns Must be Shipped Freight Prepaid.
 Do Not Return Goods Without Our Permission.